

HAMMER

WINCH



HMW Hydraulic Owner's Guide

HMW10, 10000 kg

HMW12.6, 12600 kg

HMW14.2, 14200 kg



TABLE OF CONTENTS

INTRODUCTION

SAFETY INSTRUCTIONS

GENERAL RULES OF TOWING LOAD

GENERAL ASSEMBLY INSTRUCTIONS

HYDRAULIC SYSTEM INSTALLATION

ROPE ASSEMBLY

GENERAL OPERATION INSTRUCTIONS

USE OF MANUAL CLUTCH

USE OF PNEUMATIC CLUTCH

TOWING A LOAD OPERATION

GENERAL MAINTENANCE

HYDRAULIC DIAGRAM

PROBLEM-CAUSE-SOLUTION TABLE

WARNINGS REGARDING THE ROPE

DECLARATION OF CONFIRMITY

WARRANTY TERMS AND WARRANTY CERTIFICATE



INTRODUCTION

This winch is produced only for load pulling purposes only in the specified capacities.

Do not use for lifting...

ABOUT THE GUIDE

This user and maintenance manual contains the general maintenance and usage instructions of Hammerwinch branded winch. Before you start using the winch, be sure to read this manual carefully. Follow the maintenance and safety instructions given in this guide for safe and long-lasting use. If you encounter a different point from what is specified in this manual, please contact the Hammerwinch company.

SAFETY INSTRUCTIONS



WARNING !!!

TO AVOID ACCIDENTS AND INJURIES PLEASE READ AND APPLY THE SAFETY INSTRUCTIONS!

- ✓ **Do not use without being fully familiar with all the control and operating apparatus on the winch.**
- ✓ **Keep this manual in a safe place for general maintenance instructions.**
- ✓ **Rope breakage or unexpected movement of the load can cause fatal accidents. That is why you should keep people at a safe distance from the work area.**
- ✓ **Do not use the clutch while the winch is under the load. This may cause the load to run backwards and cause accidents.**
- ✓ **Do not control the winch with sudden movements while it is under load. This may cause damage to the winch and accidents.**
- ✓ **Stay away from the moving parts, moving rope and load.**



- ✓ Before starting the towing, make sure that the work area and the surrounding of the load are clean.
- ✓ Never operate a winch while under the influence of alcohol, drugs or medicine.
- ✓ Use only parts and accessories recommended by the manufacturer.
- ✓ If an unexpected noise or vibration comes from the winch, stop the operation immediately and check the system.
- ✓ Do not use the winch beyond the purpose.
- ✓ Never exceed the winch rated capacity.
- ✓ Do not try to pull the load directly from the right or left side of the winch. Use a steering block in such cases.
- ✓ Clean the route if there are barriers to prevent the load.
- ✓ Before starting the operation, consider all the conditions such as incline, soil structure, condition of the load (in a wheeled and walking or draggable situation).
- ✓ Always mount the rope on a solid point of the load.
- ✓ Before starting the operation, wear your necessary work safety clothes such as gloves, helmet, and iron-tipped shoes.
- ✓ Before starting the operation, be sure to check the connection bolts of the winch, hydraulic connections, and the rope.
- ✓ If the rope is damaged, replace it.

HAMMER WINCH

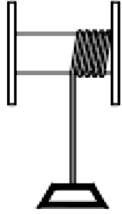

The last five winding absolute must remain on the drum.

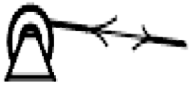

Always keep a safe distance from the operating area, as the ropes can break suddenly and cause fatal accidents.



Never use a winch to lift or move people.



Always wear eye protection.



Always wear your helmet.



Always wear heavy protective gloves.



Always wear steel toed shoes.

GENERAL RULES OF TOWING LOAD

Pulling Angle

For a long life of the rope, pull the load with a maximum angle of 15° horizontally and vertically. If you tow at steeper angles, the rope is not wound properly on the drum and the product and the rope may be damaged.

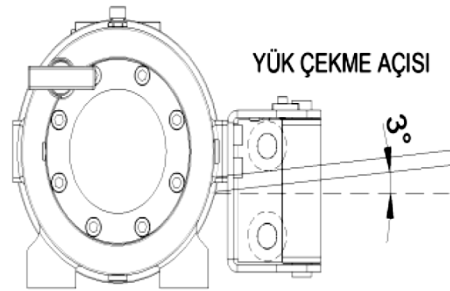
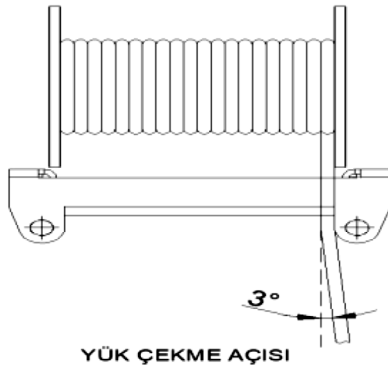

Pulling Capacity

The winches are always classified according to the towing capacity at the bottom winding of the drum. For this reason, please take this into consideration when buying a winch. The pulling capacity and speed change according to the rope winding order. In the bottom-winding, the winch provides the highest towing capacity and the lowest towing speed. In the top winding, it provides the lowest pulling force and the highest winding speed.

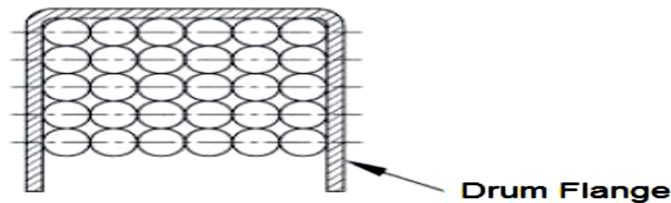
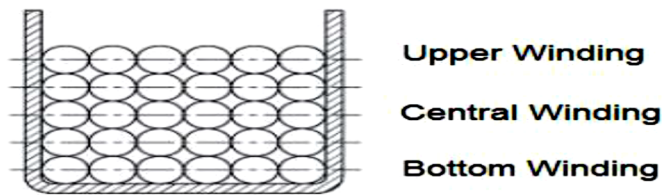

HAMMER WINCH

Required Pulling Force

In order for pull the load, factors such as the weight of the load as well as the slope and the structure of the ground aggravate the load. Soil structure can be diversified as mud, shaft, sand, or gravel. Thus, before starting the towing process, you can find the required towing force by using the calculation methods and tables given below.

$$RPF = (Wt \times S) + (Wt \times G)$$

RPF: Required towing force

Wt : Weight of the load

S : Coefficient of Surface Friction tied to Ground

G = Slope Coefficient

SLOPE %	angle(°)	slope coefficient(G)	SOIL TYPE	FRICITION COEFFICIENT (S)
5%	3°	0,06	ASPHALT	0,050
10%	6°	0,11	GRASS	0,175
20%	11°	0,2	GRAVEL	0,250
30%	17°	0,3	SAND	0,325
50%	26°	0,44	MUD	0,425
70%	35°	0,58	SHAFT	0,625
100%	45°	0,71		

For example, When a 3,000kg vehicle is on a 100% slope and stuck in shaft, the requited pulling force is calculated as follows:

Wt: 3,000 kg, S: 0.625 G: 0.71

$$RPF = (Wt \times S) + (Wt \times G)$$

$$= (3,000 \text{ kg} \times 0.625) + (3,000 \text{ kg} \times 0.71)$$

$$= 1,875 \text{ kg} + 2,130 \text{ kg}$$

$$= 4,005 \text{ kg Required Pulling Force}$$

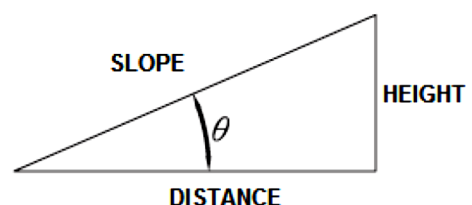

HAMMER WINCH

ASSEMBLY INSTRUCTIONS

The winch can be mounted a vehicle **in two ways**, as shown below. Please pay attention to the technical specifications in this manual when assembling the winch for a safe operation.

The mounting method is mounting on a flat sheet. The thickness of the sheet on which you will mount the winch must be **at least 10mm**, flat and smooth. (For Series 4.0 – 5.0 – 5.8 – 6.8 – 7.8 PHT)

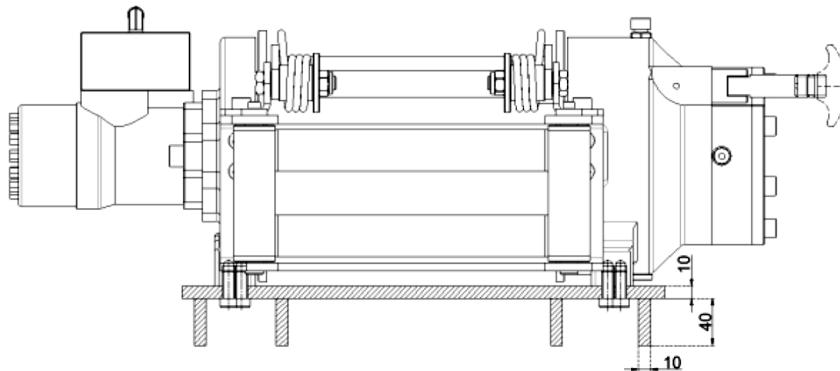

4.0 – 5.0 – PHT series

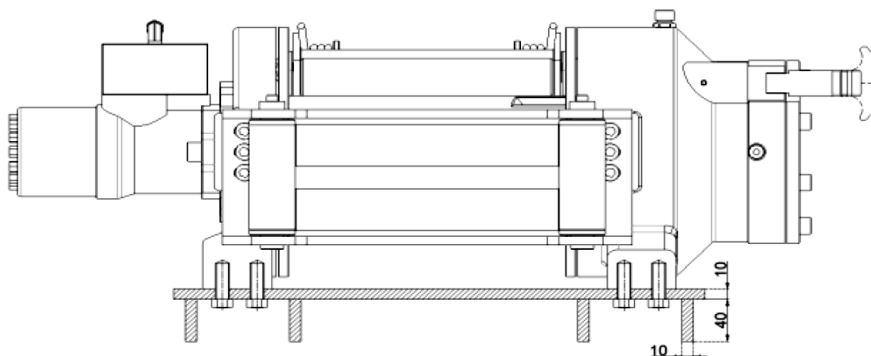

5.8 – 6.8 – 7.8 PHT Series

The mounting method is mounting on a flat sheet. The thickness of the sheet on which you will mount the winch must be **at least 15mm**, flat and smooth (For Series 10.0 – 12.0 - 15.0 PHT-N)

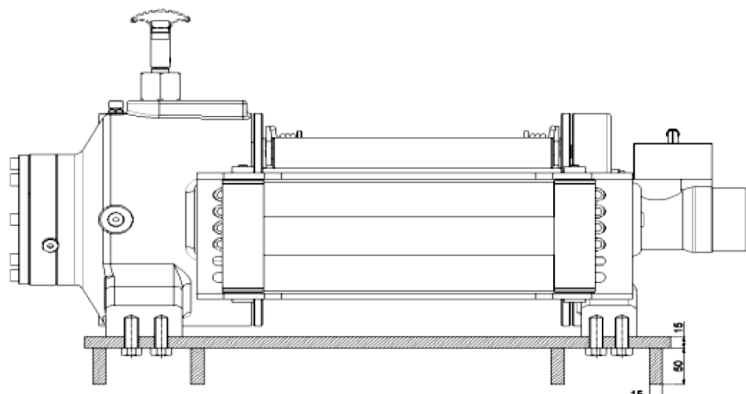

10.0 – 12.0 - 15.0 PHT-N Series

HAMMER WINCH

Hydraulic System Installation

Depending on your rope winding style, you can assemble the hydraulic connections as shown in the pictures below. (The roller fairlead can not be used in over wound.) (**HMW 3.6 / 4.3 / 5.6 / 6.6 / 7.6 EN - HMW 4.0 / 5.0 / 5.8 / 6.8 / 7.8 / 9.0 / SAE - HMW 8.0 / 10.0 / 12.0 / 13.5 / 15.5 / 18.0 LBS-SAE & HMW 10.0 / 12.0 / 14.2 EN – HMW 10.0 / 12.0 / 15.0 - HMW 10.0K / 12.0K / 15.0K SAE**)

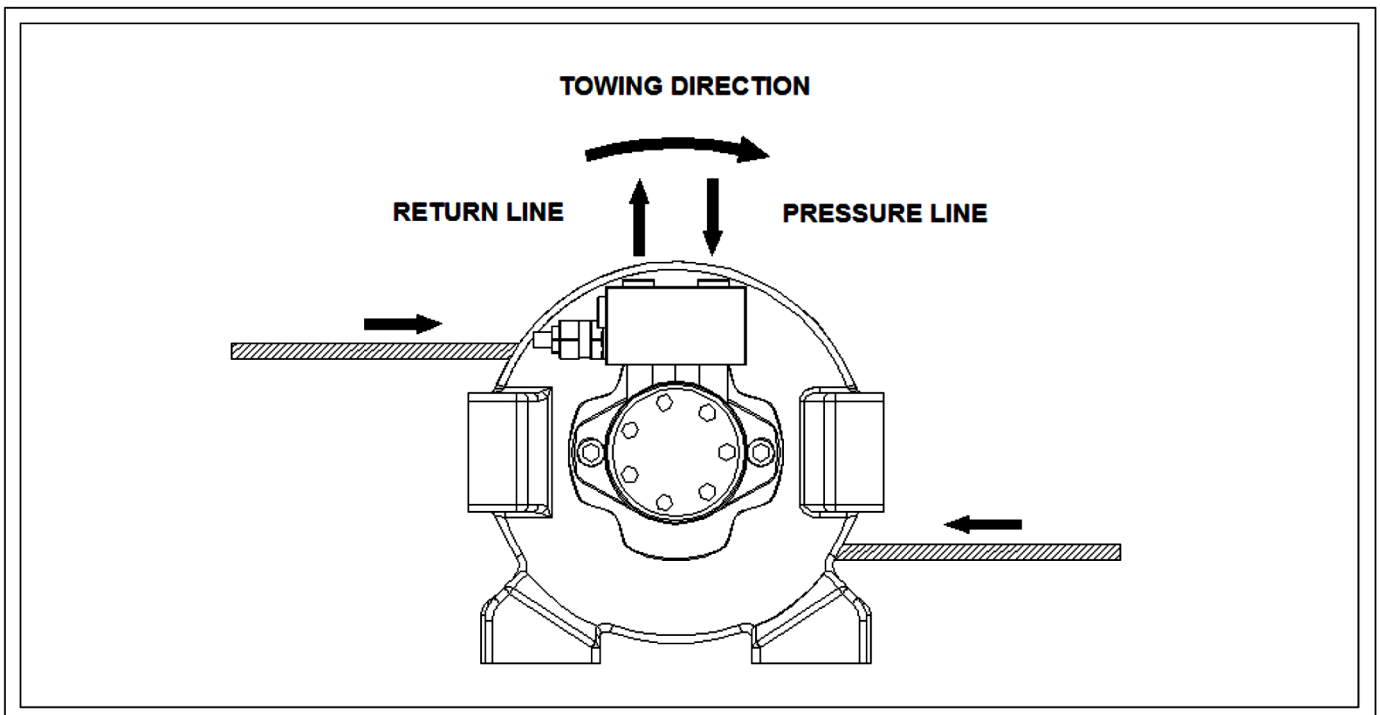
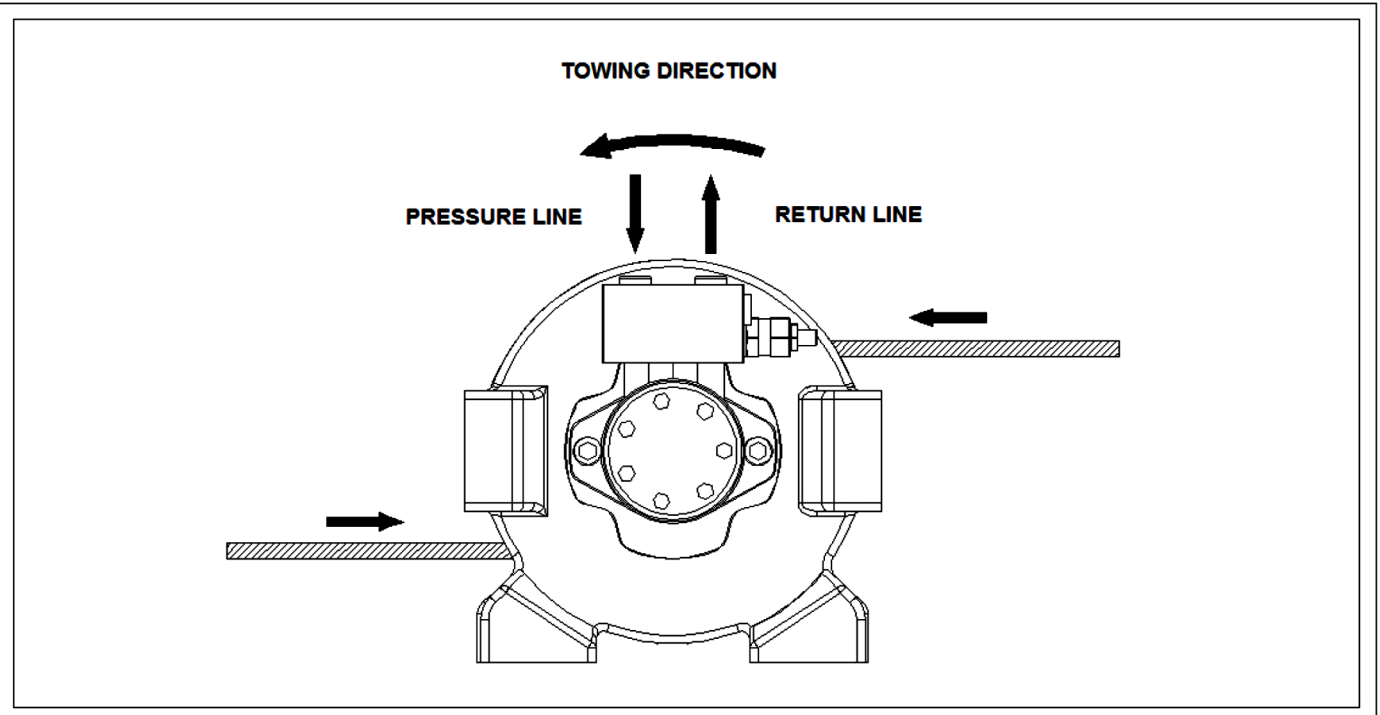

Rope Assembly

Rope mounting method depends on where the winch will be mounted.

- If you are mounting the winch on the plate and with the front roller, you should mount the rope as shown in the figure and always fix the rope by passing it under the winch.

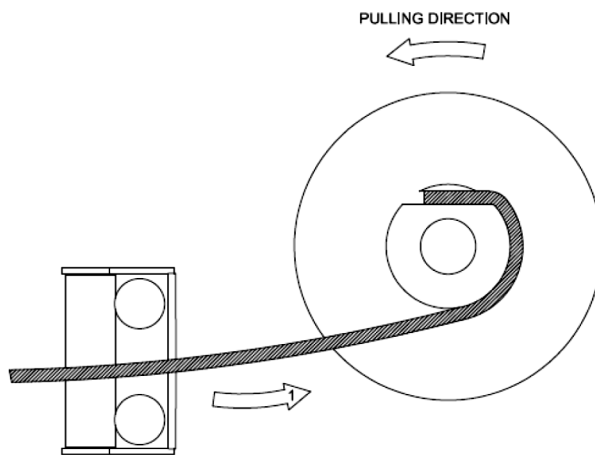

- If you are going to wind the rope of the winch from the top, you can not use the roller fairlead. (The rope should be mounted as in the bottom picture.)

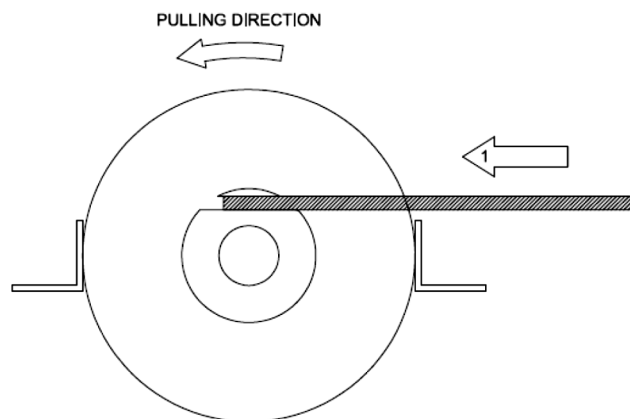

ALWAYS CHECK THE ROPE FIXING BOLT OR WEDGE. A LOOSE THE CONNECTION BOLT OR WEDGE MAY CAUSE THE ROPE TO DISCLOSE AND RESULT IN SERIOUS ACCIDENTS.

✓ GENERAL INSTRUCTIONS

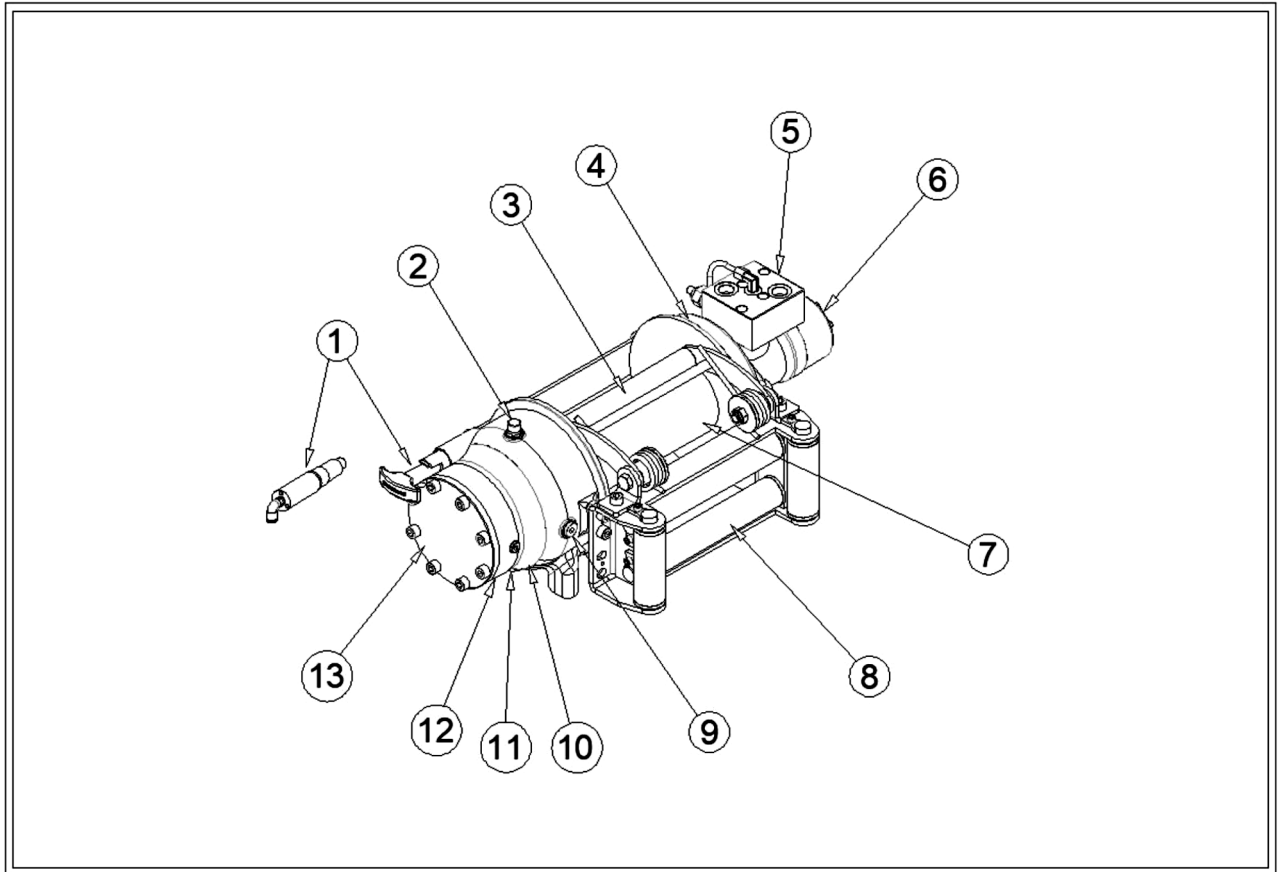

This drawing is for series HMW 3.6 / 4.3 / EN - HMW 4.0 / 5.0 / SAE - HMW 8.0 / 10.0 / 12.0 LBS-SAE

- 1- Manual or pneumatic clutch
- 2- Gear box oil filler plug
- 3- Cable tensioner
- 4- Rear body
- 5- Brake valve
- 6- Hydromotor
- 7- Drum (spool)
- 8- Roller fairlead
- 9- Oil level control plug
- 10- Main body
- 11- Oil drain plug
- 12- Brake body
- 13- Brake cover

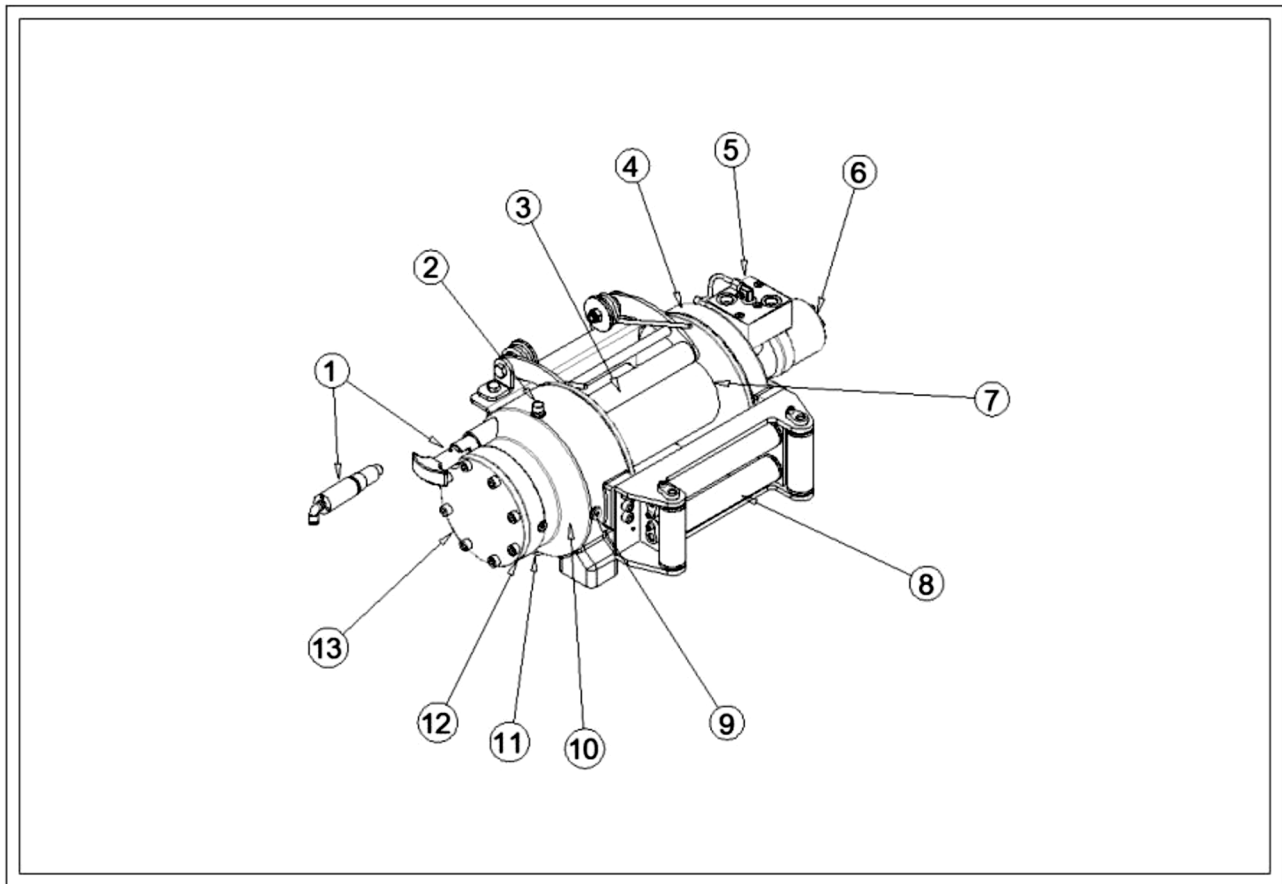

This drawing is for series HMW 5.6 / 6.6 / 7.6 / EN - HMW 5.8 / 6.8 / 7.8 / SAE - HMW 13.5 / 15.5 / 18.0 LBS-SAE

- 1- Manual or pneumatic clutch
- 2- Gear box oil filler plug
- 3- Cable tensioner
- 4- Rear body
- 5- Brake valve
- 6- Hydromotor
- 7- Drum (spool)
- 8- Roller fairlead
- 9- Oil level control plug
- 10- Main body
- 11- Oil drain plug
- 12- Brake body
- 13- Brake cover



CHECK THE FOLLOWING PRECAUTIONS BEFORE THE TOWING OPERATION!

- ✓ Check all hydraulic connections against loosening and leakage.
- ✓ Check whether there is damage on the rope.
- ✓ Check the hydraulic oil level from the oil tank.
- ✓ Make sure that no one is in the work area.

To unwinding the rope manually, proceed as follows:

- Pull the clutch in the direction of arrow No.1
- Then, turn the clutch in the direction of Arrow No.2 with 90° and release it.

Through this process, we unlock the manual rope unloader.

Then, manually pull the rope towards the load.



LEAVE AT LEAST FIVE FULL TURNS OF WIRE ROPE ON THE DRUM!!!

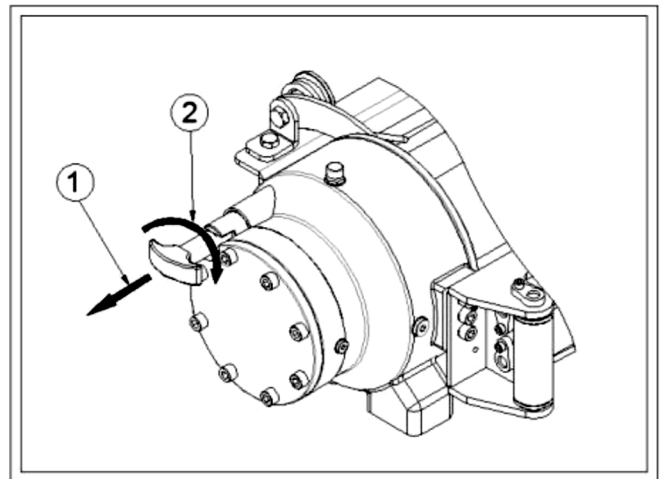

Proceed as follows to bring the winch into the pulling position:

-Pull the clutch in the direction of arrow No.1 direction.

-Then, turn the clutch in the direction of Arrow No.2 with 90° and release it. .

This Operation ensures that the winch is locked.

!! After making sure that the clutch is in place, it is started to pull by giving power to the winch with the Hydraulic control han

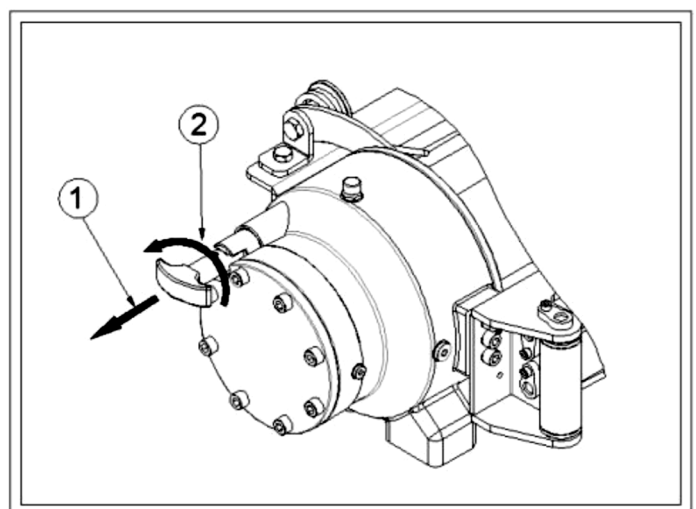

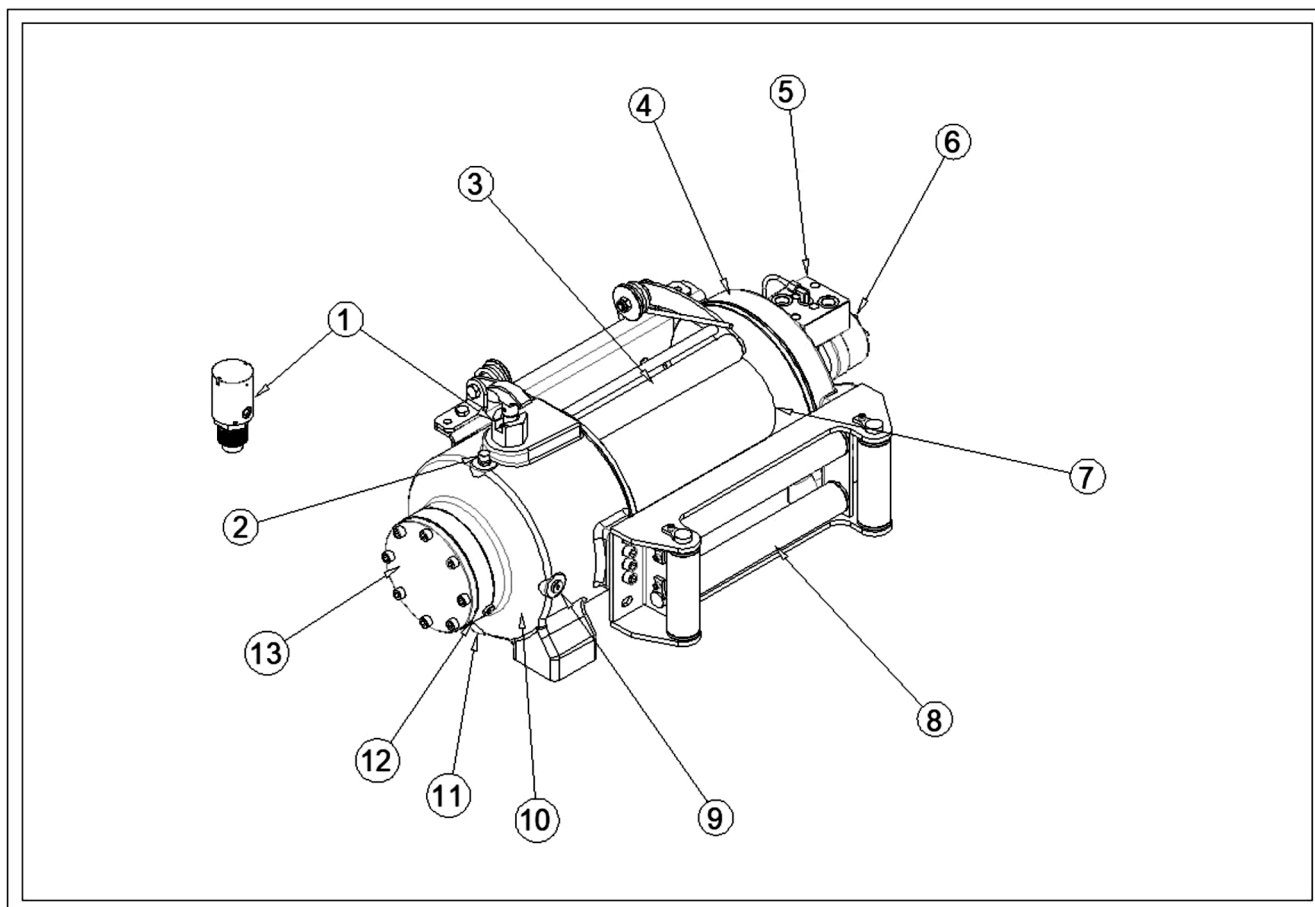

This drawing is for series **10.0 /12.0 /14.2 EN – HMW 10.0 /12.0 /15.0 – HMW 10.0K /12.0K /15.0K SAE**

- 1- Manual or pneumatic clutch
- 2- Gear box oil filler plug
- 3- Cable tensioner
- 4- Rear body
- 5- Brake valve
- 6- Hydromotor
- 7- Drum (spool)
- 8- Roller fairlead
- 9- Oil level control plug
- 10- Main body
- 11- Oil drain plug
- 12- Brake body
- 13- Brake cover

Follow this way to unwinding the rope manually:

- Pull the clutch in the direction of arrow No.1
 - Then, turn the clutch in the direction of Arrow No.2 with 90° and release it.
- Through this process, we unlock the manual rope unloader.
- Then, manually pull the rope towards the load.

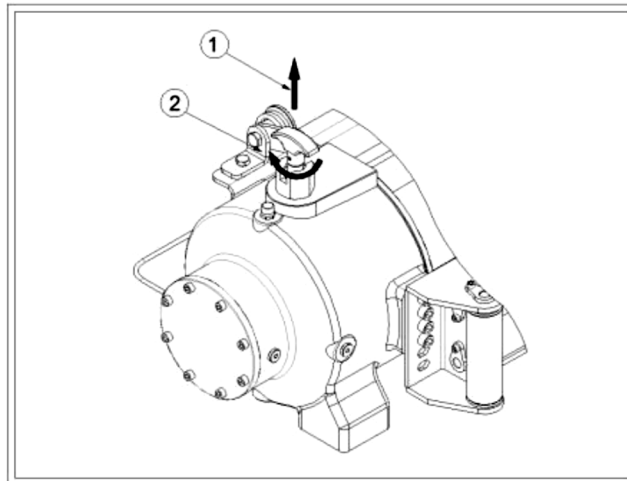

LEAVE AT LEAST FIVE FULL TURNS OF WIRE ROPE ON THE DRUM!!!

Proceed as follows to bring the winch to the load pulling position:

- Pull the clutch in the direction of arrow No.1 direction.
- Then, turn the clutch in the direction of Arrow No.2 with 90° and release it. .

This Operation ensures that the winch is locked.

!! After making sure that the clutch is in place, It is started to pull by giving power to the Winch with the Hydraulic control handle.

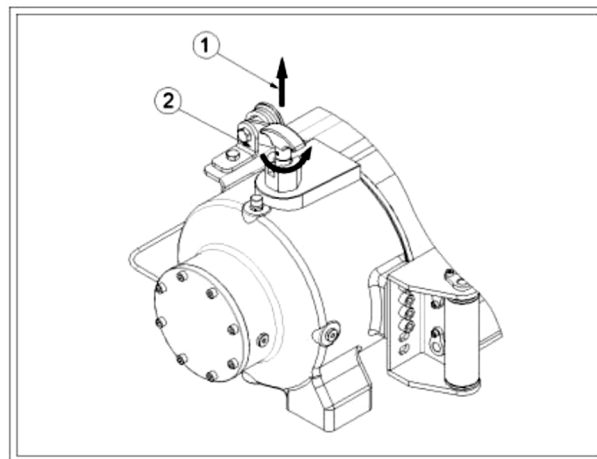

HAMMER WINCH

USE OF PNEUMATIC CLUTCH

To unwinding the rope manually in pneumatics, follow the procedure below;

Compressed air is applied to the coupling at point P. (Pressure to be applied: **Min 9 bar- Max 12 bar (Min 130 psi - Max 174 psi)**)

To bring the load to the pulling load position pneumatically, proceed as follows:

Cut off the compressed air applied to the coupling at point P. After making sure that the clutch is in place, it is started to pull by giving power to the winch with the Hydraulic control handle.

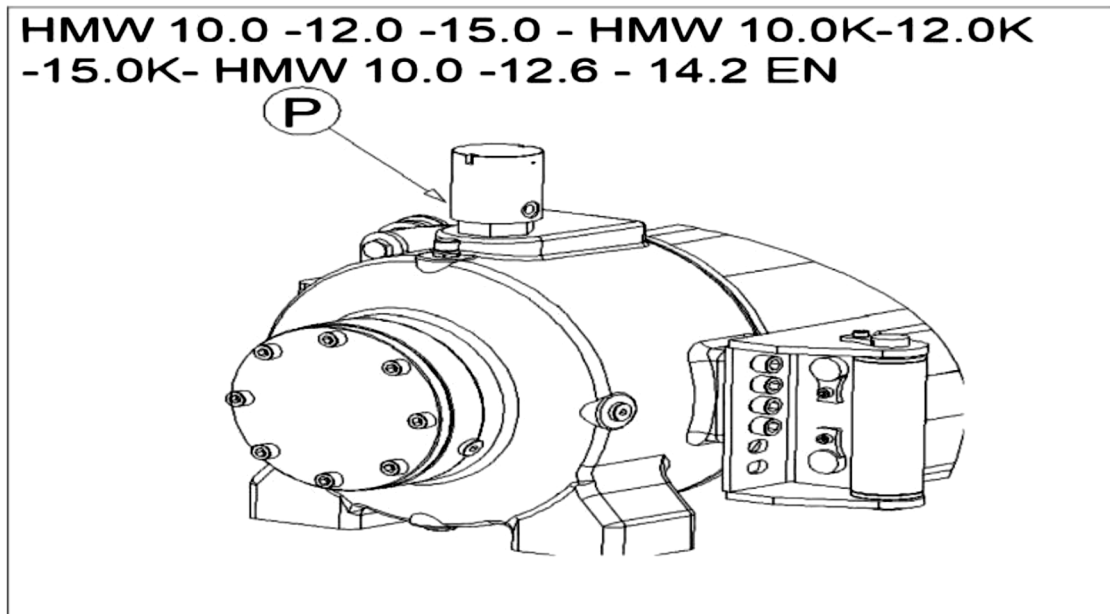
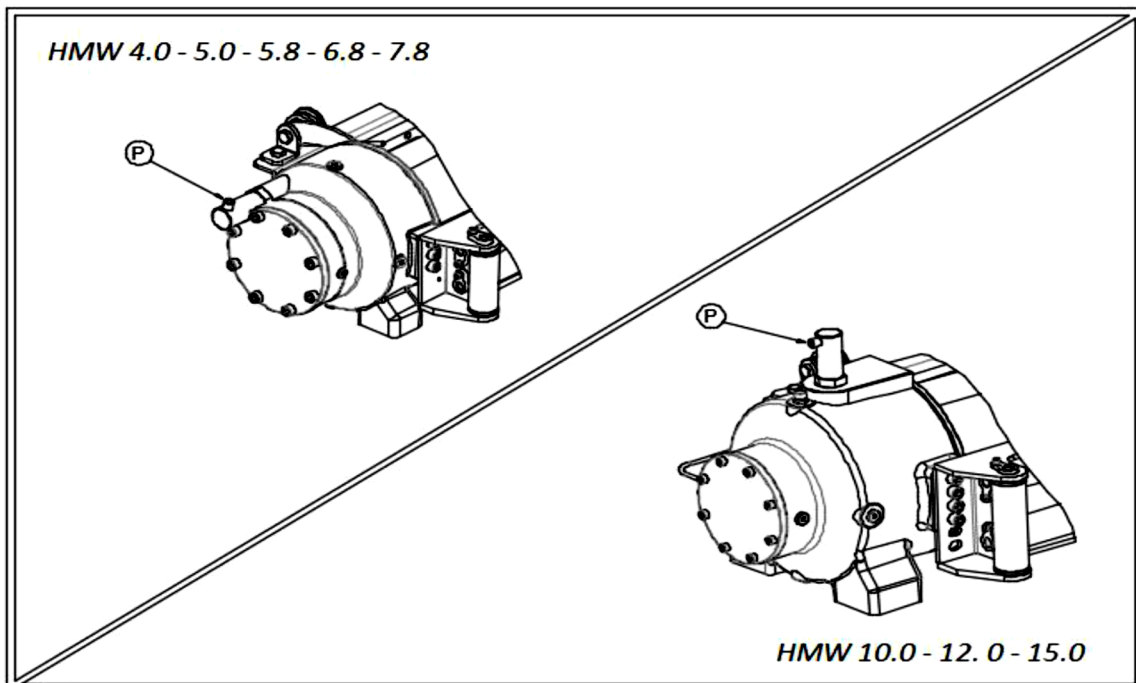

- TOWING A LOAD OPERATION



Please follow the rules below during the towing process:

- ✓ Avoid sudden movements during towing and start the operation by pushing the control handle slowly.
- ✓ Make sure that there is no one in the operation area.
- ✓ Do not try to pull a load more than its capacity with the winch.

Place the vehicle in the same line as the load as possible before starting the towing process.

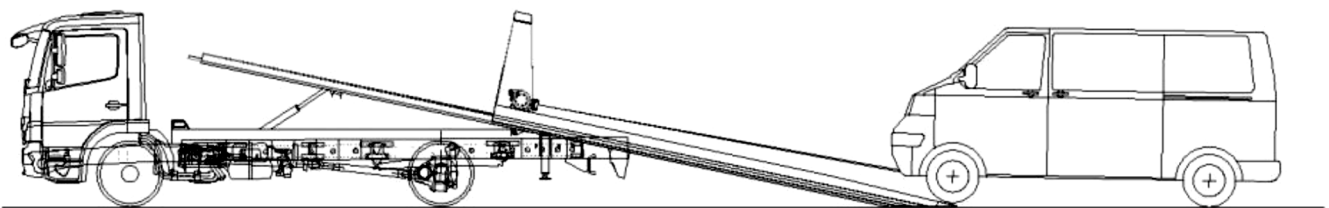

HAMMER WINCH

If this is not possible, direct the rope towards the load with the help of pulleys and reel as seen in the image below.

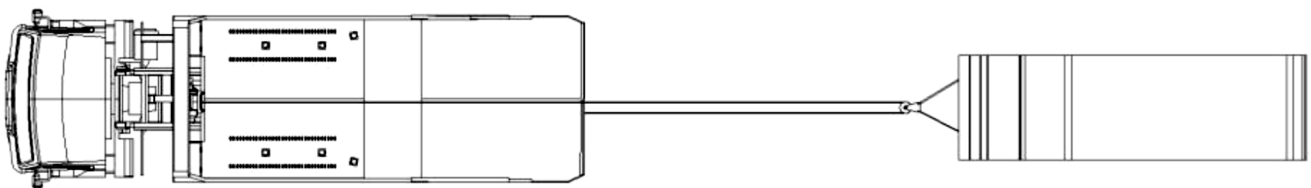
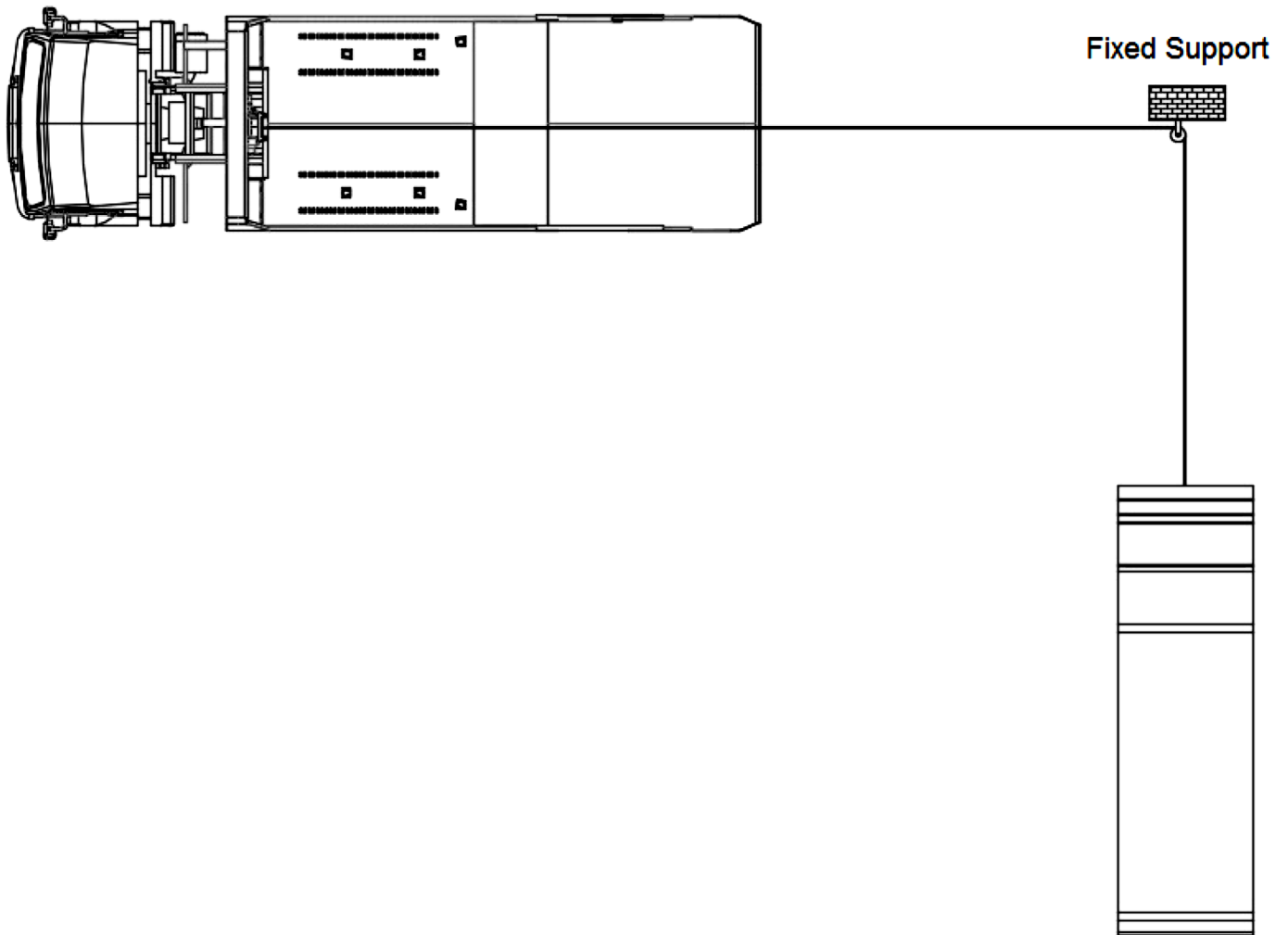

By using a pulley system, you can tow 6000 kg load with 3000kg pulling force as in the picture above.

GENERAL MAINTENANCE

Follow the general maintenance and safety instructions written in this manual for a safe and long-lasting use.

If you do not comply, the winch may malfunction and cause accidents.



DO OIL CHANGE EVERY TWO YEARS!

GEAR OIL CHANGE

FOR HMW 3.6 / 4.3 / 5.6 / 6.6 / 7.6 EN - HMW 4.0 / 5.0 / 5.8 / 6.8 / 7.8 / 9.0 / SAE - HMW 8.0 / 10.0 / 12.0 / 13.5 / 15.5 / 18.0 / LBS-SAE SERIES

- First, open the gear box oil filler plug, number 1.
- Then, open the oil drain plug shown with number 2 and pour the used oil into a container.
- After all the oil has been drained, close the oil drain plug and remove the oil level plug indicated by number 3.
- Fill gear oil with **85W 90** quality up to the level of the oil level plug and close the plug.
- Complete the process by closing gear oil filler plug (plug no. 1)

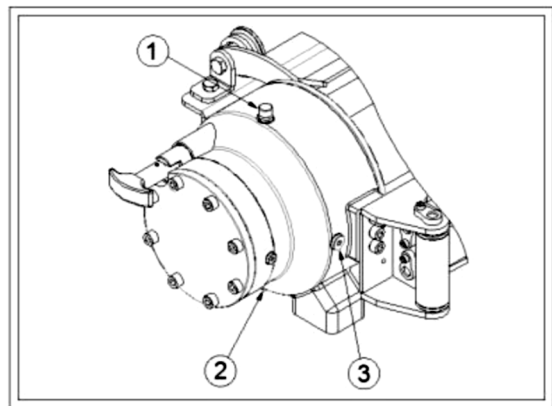

GEAR OIL CHANGE

FOR 10.0 / 12.0 / 14.2 EN-HMW 10.0 / 12.0 / 15.0 SERIES

- First, open the gearbox oil filler plug indicated with number 1.
- Then, open the oil drain plug shown with number 2 and pour the used oil into a container..
- After all the oil has been drained, close the oil drain plug and remove the oil level plug indicated by number 3.
- Fill gear oil with 85W 90 quality up to the level of the oil level plug and close the plug
- Finally, close the gearbox oil filler plug (plug no.1) and finish the process.

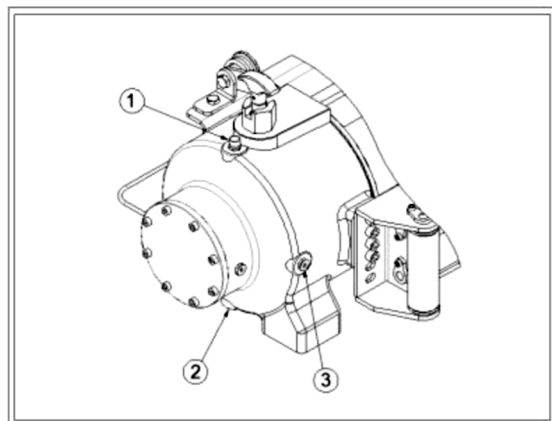

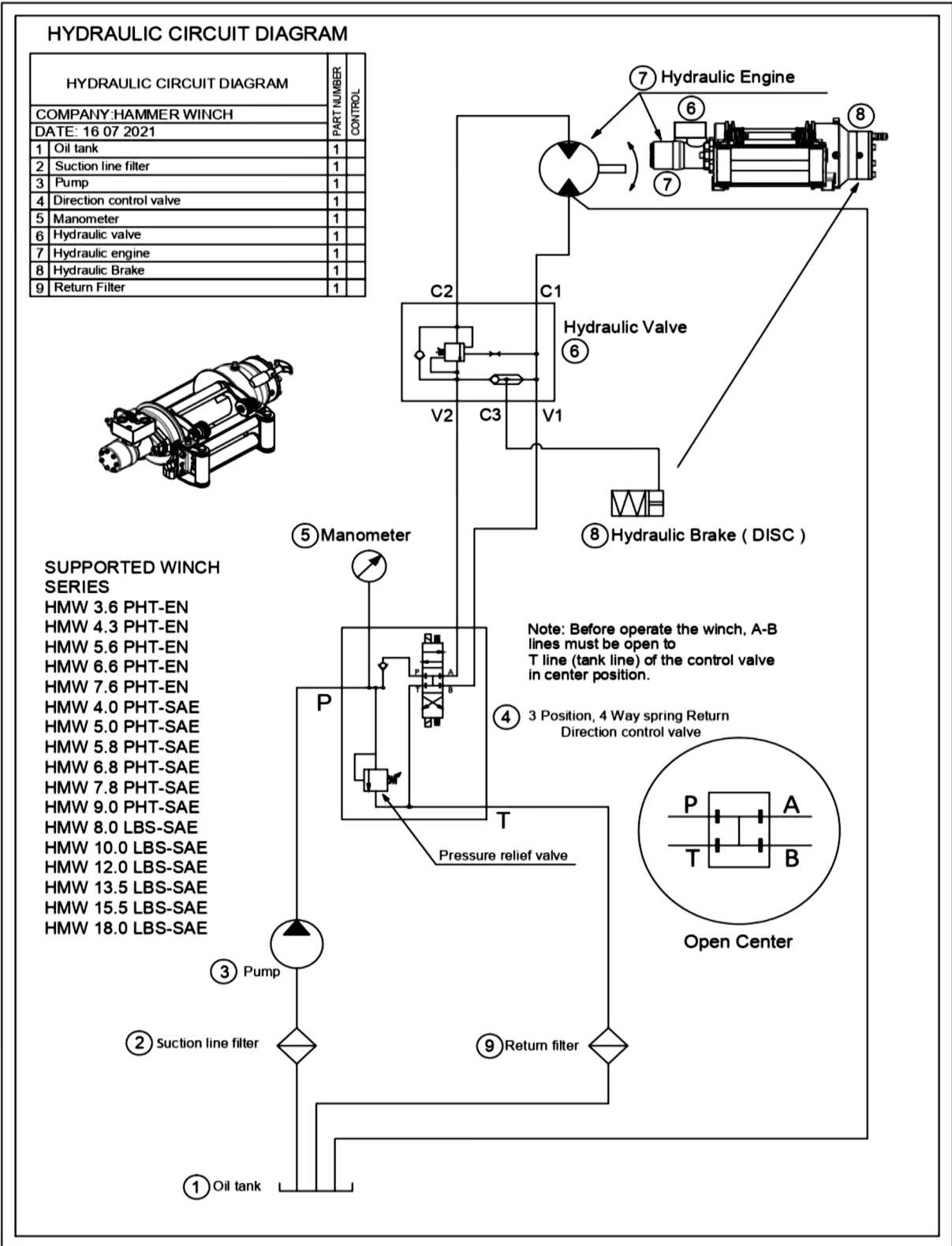

HYDRAULIC CIRCUIT DIAGRAM

HYDRAULIC CIRCUIT DIAGRAM		PART NUMBER	CONTROL
COMPANY:HAMMER WINCH			
DATE: 04 05 2020			
1	Oil tank	1	
2	Suction line filter	1	
3	Pump	1	
4	Direction control valve	1	
5	Manometer	1	
6	Hydraulic valve	1	
7	Hydraulic engine	1	
8	Hydraulic Brake	1	
9	Return Filter	1	

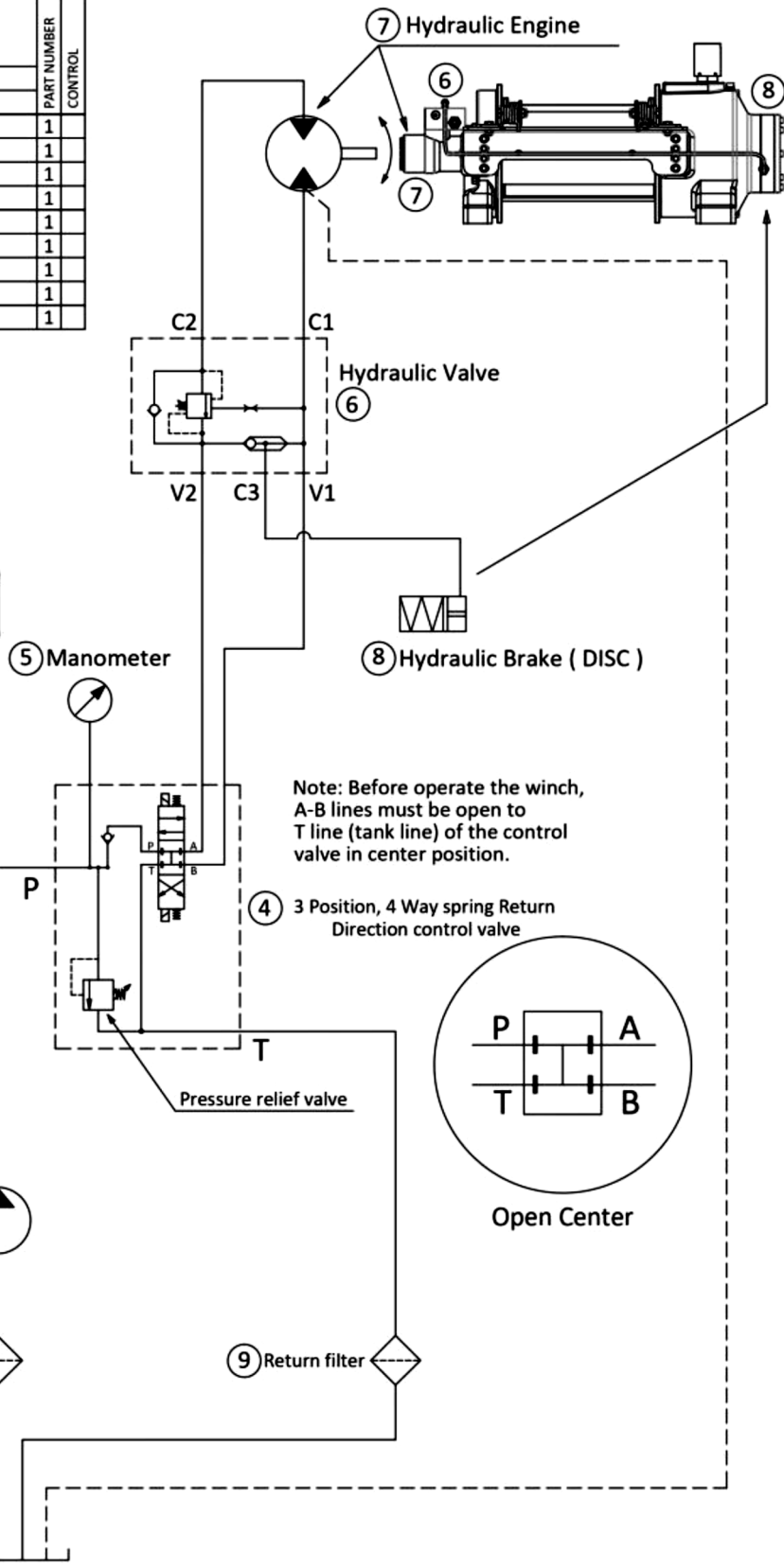
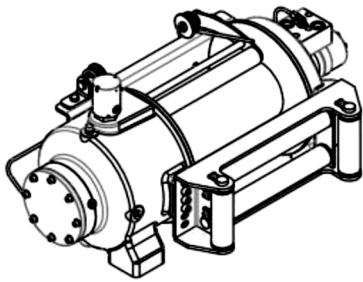

SUPPORTED WINCH SERIES

- HMW 10.0 PHT-EN
- HMW 12.6 PHT-EN
- HMW 14.2 PHT-EN
- HMW 10.0 PHT
- HMW 12.0 PHT
- HMW 15.0 PHT
- HMW 10.0 PHT-K
- HMW 12.0 PHT-K
- HMW 15.0 PHT-K

Note: Before operate the winch, A-B lines must be open to T line (tank line) of the control valve in center position.

④ 3 Position, 4 Way spring Return Direction control valve

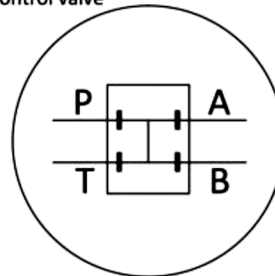

Open Center

PROBLEM-CAUSE-SOLUTION TABLE

PROBLEM	CAUSE	SOLUTION
- Winch does not work	- No oil flow	- Check the hydraulic oil level. - Check all hydraulic systems and components for leaks.
	- Hydraulic brake does not release	- Check the pressure at the brake input. (min. 35bar) - Check the brake valve for contamination. Clean it, if soiled. - Check the brake hose.
	- The PTO is not engaged.	- Engage the PTO
	- Damaged Hydromotor	- Change the hydromotor
	- Damaged pump	- Replace the pump
	- Damaged hydraulic system	- Replace the damaged part.

PROBLEM	CAUSE	SOLUTION
- Rope drum (reel) does not spin	- Non-locking clutch	- Move the reel back and forth using the control valve. The locking pin will engage.
	- Damaged return spring on the clutch	- Please contact the manufacturer.
	- Damaged gear system	Please contact the manufacturer.
-The clutch of the rope drum does not lock	- Damaged or stuck clutch shaft	Please contact the manufacturer.
	- Damaged return spring on the clutch	Please contact the manufacturer.
	-Non-snap pin into the slot	- Move the reel back and forth using the control valve. The locking pin will engage.
- The winch shakes and makes noise during pulling	- Damaged Hydromotor	- Please contact the manufacturer.
	- Dirty hydraulic oil and filters	- Clean or replace the hydraulic oil and filters
	- Air in the hydraulic system	- Bleed the system
	- Dirty control valve	- Clean the control valve
	- Defective hydraulic brake	- Please contact the manufacturer.
	- Low oil flow (Flow rate) or low oil pressure (Bar)	- Increase the oil flow of the system.

HAMMER WINCH

The rope used in the rope drum should not be used for damages caused by wear and corrosion. Otherwise, it may lead to dangerous accidents. The pictures that need to be taken about this are shown below. In such cases, the rope must be replaced with a new rope.

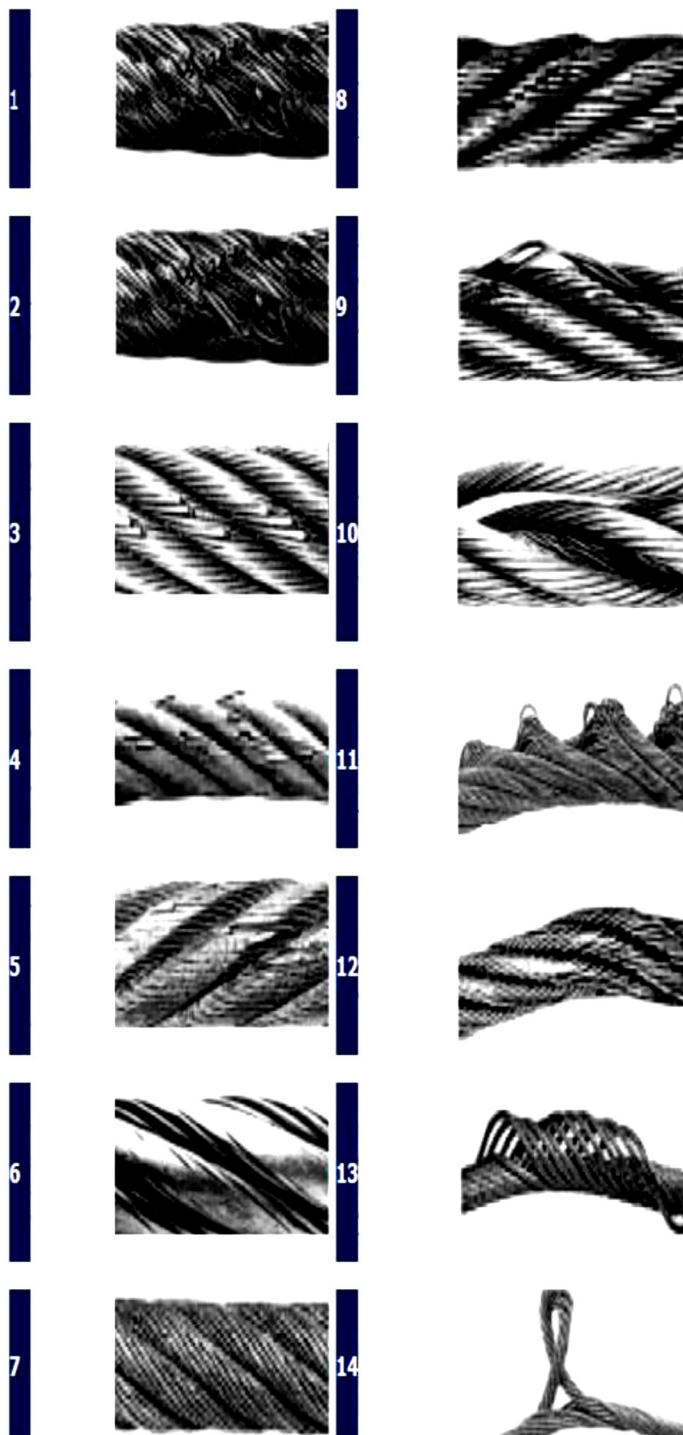



DECLARATION OF CONFIRMITY

We, as HAMMER WINCH, declare that the 'winch models' produced by us are produced in accordance with the following standards. (Standards may vary according to models.)

- CE Machinery Directive 2006/42/EC
- EN 14492-1: Compliant
- SAE J706 rating

Terms of Guarantee:

- If the winch is brought in parts it is not covered by the warranty.
- Any damaged part is not covered by the warranty.
- A product failure caused by the removal or replacement of any part of the rope drum is not covered by the warranty.
- Winch that are seen to be used badly are out of warranty.

Winch can only be used for rescue and towing purposes, rope drums used for other purposes are out of warranty.
- Warranty covers manufacturing defects, workmanship and material defects and mechanical parts.
- Steel rope and hook are not covered by the warranty.
- Warranty coverage; This does not apply in cases of normal wear and tear, misuse, collision, overload, modification, misapplication, improper assembly, faulty service and if the drum has been in an accident.
- The customer is obliged to disassemble the rope drum and send it to the factory address with the transport company determined by the "Hammer winch" company.
- All transportation costs are paid by the customer.
- The product owner is responsible for all shipping costs until it is accepted that the problem with the product is within the scope of warranty.
- In case of any part that needs to be modified is sent to the owner, and if the problem will be solved, all of the costs will be paid by " Hammerwinch and a spare part will be sent. In this case, " Hammerwinch " can request the damaged parts back.
- "Hammerwinch" is not responsible for the assembly and installation costs of the product.
- "Hammerwinch" reserves the right to make changes in the warranty conditions



CERTIFICATE OF GUARANTEE

ITEM

TYPE :

MODEL :

SERIAL NUMBER:

WARRANTY APPROVAL DATE:



Fabrika : İstanbul yolu 31. Km 2073 Sokak No :23 A/B Kazan / ANKARA
Showroom : 1200 Sokak No: 23 Ostim / ANKARA

Please contact us for any technical problems or issues.

hammerwinch@hammerwinch.com