

INSTRUCTIONS FOR OVERHAUL OF RAMEY RE 12000 SERIES WINCH

DISASSEMBLY

1. Drain oil from gear housing by removing plug #52 from bottom of gear housing. Remove relief fitting #48 and reducer #51 from top of gear housing.

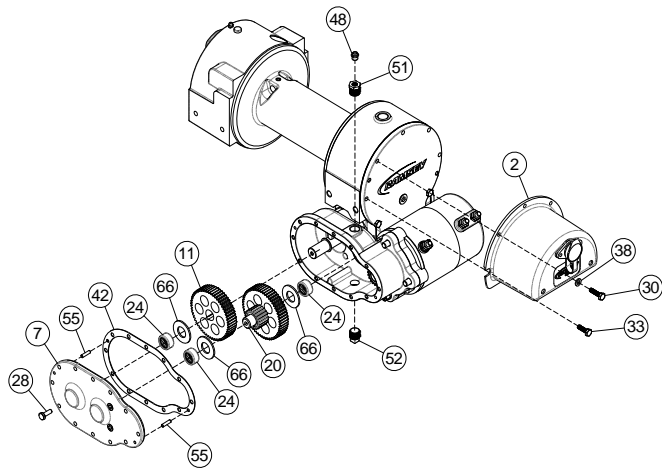
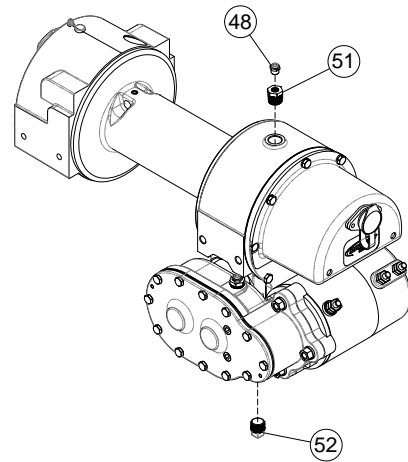

2. Drain oil from spur gear housing by removing #52 plug. Remove cover #7 and gasket #42 from spur gear housing by unscrewing twelve capscrews #28. Slide gear #11 from end of worm shaft. Remove spur gear shaft #20, with gears attached. Check bearings #24 and thrust washers #66 for signs of wear, replace if necessary. Remove old bearing and press new bearings into place.

Remove solenoid assembly #2 by unscrewing capscrews #30. Disconnect solenoid cables from motor. Make note of which terminals cables are attached to.

3. Remove key #18 and snap ring #63 from worm shaft. Remove motor #49 from spur gear housing #15 by removing (3) nuts #37 and lockwashers #39. Unscrew (4) capscrews #32 to remove spur gear box #15 and gasket #41 from gear housing. Replace lip seals #60 & #62 by pressing old seals from spur gear housing and pressing new seals into place.

Check pinion gear on motor for signs of wear. If necessary replace motor.

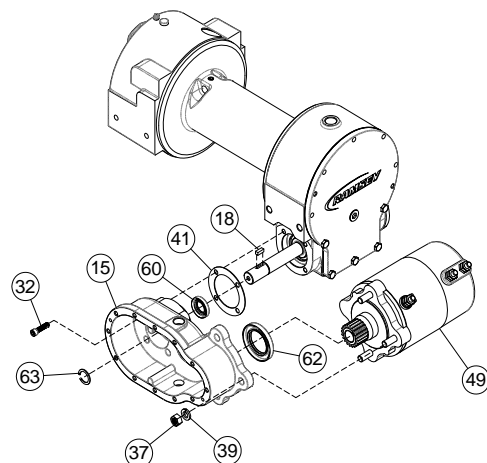

- Slide clutch housing #16 from end of drum shaft. Slide jaw clutch #6 from end of drum shaft.

Remove (2) keys #45 from keyways. A screwdriver can be used, at notch, to aid in removal of keys. Once keys have been removed, drum #9 and thrust washer #67 can be removed from drum shaft. Springs #64 and disc #40 can also be removed.

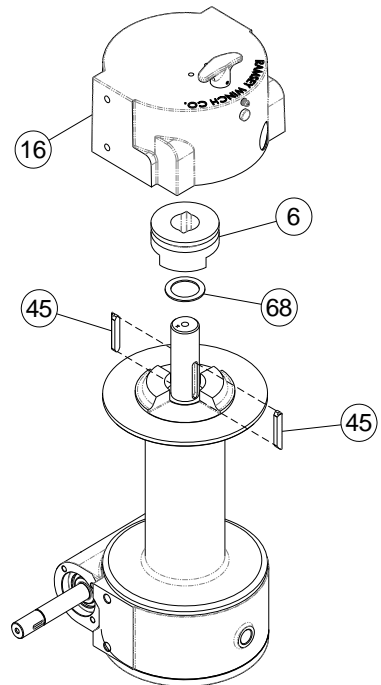
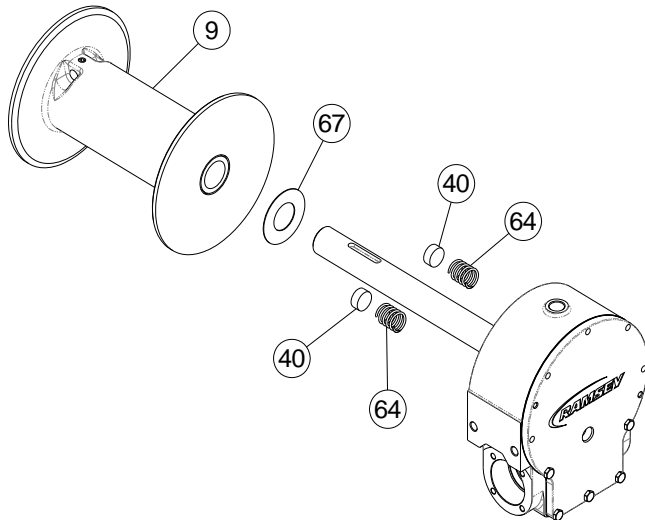

- Remove bearing cap #5 from gear housing by unscrewing four capscrews #29. Remove worm #23 and bearing #25 from gear housing. Use a soft hammer to gently tap input end of worm and drive worm and bearing from gear housing. Once worm has been removed from housing, bearing can be pressed from end of worm.

Check for signs of wear to worm #23 and bearing #25. Replace if necessary.

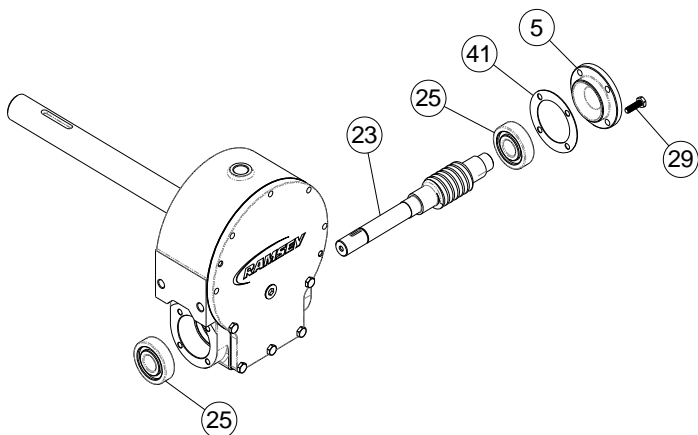

- Remove gear housing cover #8 from gear housing #17 by unscrewing five remaining capscrews #28. Place capscrews into two tapped holes of cover and tighten. This will pull the cover loose from gear housing.

Remove cover gasket #43 and pull shaft #21, with gear attached, and thrust washer #68 from gear housing.

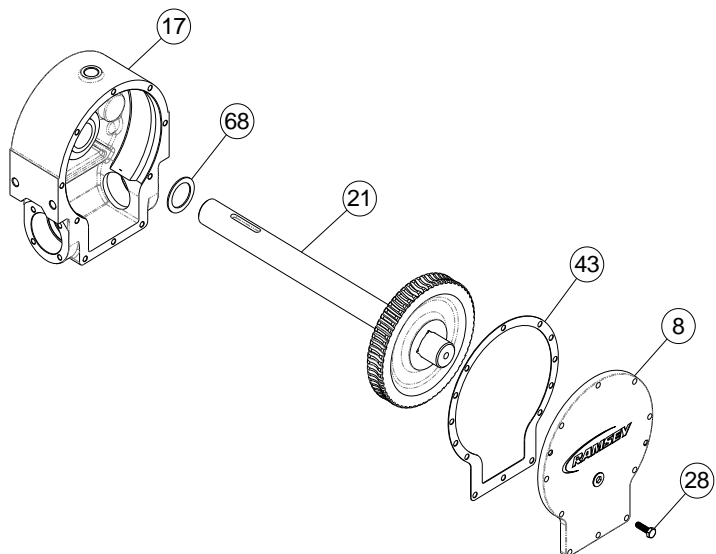

7. Check for signs of wear on gear teeth. If replacement of gear is necessary, replace as follows:

- a) Press gear #13 from shaft #21.
- b) Examine shaft keys and keyways. If distortion of keys and/or keyways is evident, shaft and keys should be replaced.
- c) Use a soft hammer to gently tap keys #46 into keyways. Press gear #13 over shaft and keys. Gear must be centered over keys.

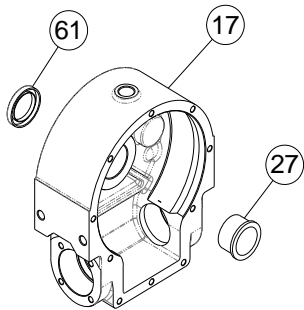
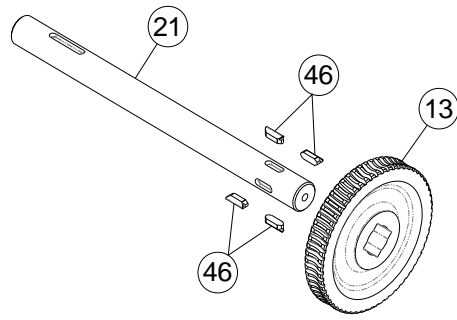

8. Remove seal #61 from back of gear housing #17. Press bushing #27 from gear housing. Press new bushing and seal back into place.

9. Check drum bushings #26 for signs of wear. Replace if necessary by pressing old bushing from drum. Press new ones into place.

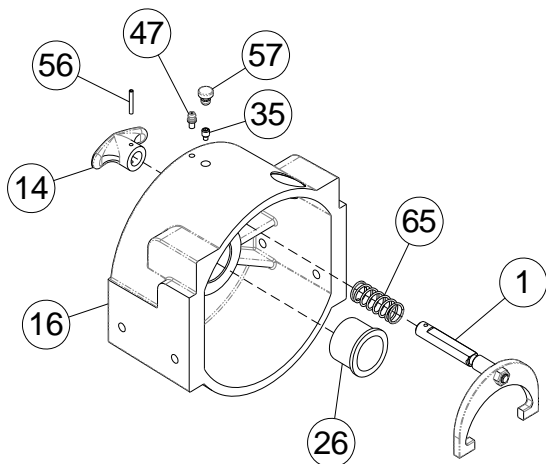
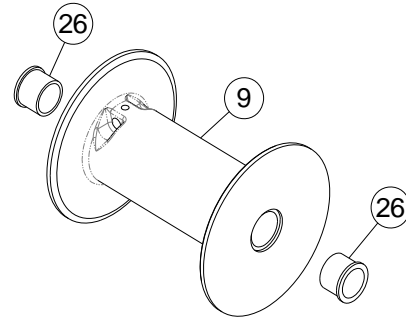

10. Examine shifter assembly #1 for damage to yoke. Yoke should be firmly attached to shaft, yet, able to swivel freely around shaft. Replace if necessary by removing pin #56 from handle #14. Remove rubber plug #57 from housing. Unscrew setscrew enough to allow shifter assembly to be removed from housing.

Check clutch housing bushing #26 for signs of wear. Remove if necessary by pressing old bushing from housing #16 and pressing new one into place.

Install new shifter assembly #1 by placing end of shaft, opposite yoke, through spring #65 and into housing #16. Attach handle #14 to shaft using roll pin #56. Tighten setscrew #35, in housing, enough to allow shifter assembly to operate properly. Replace rubber plug #57.

11. Check cover bushing #26 for signs of wear. Replace if necessary by removing old bushing and pressing new bushing into place.

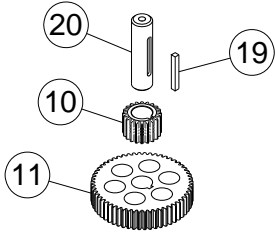
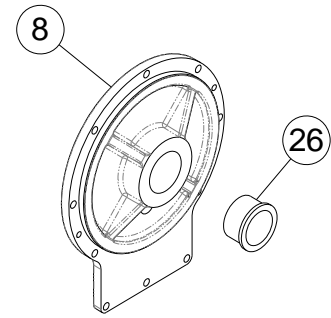

12. Check gears #10 & #11 of spur gear shaft assembly for signs of wear, replace if necessary. Press old gears from shaft #20. Tap key #19 into keyway of shaft #20. Press shaft through gears so that gears are centered on shaft and key.

RE-ASSEMBLY

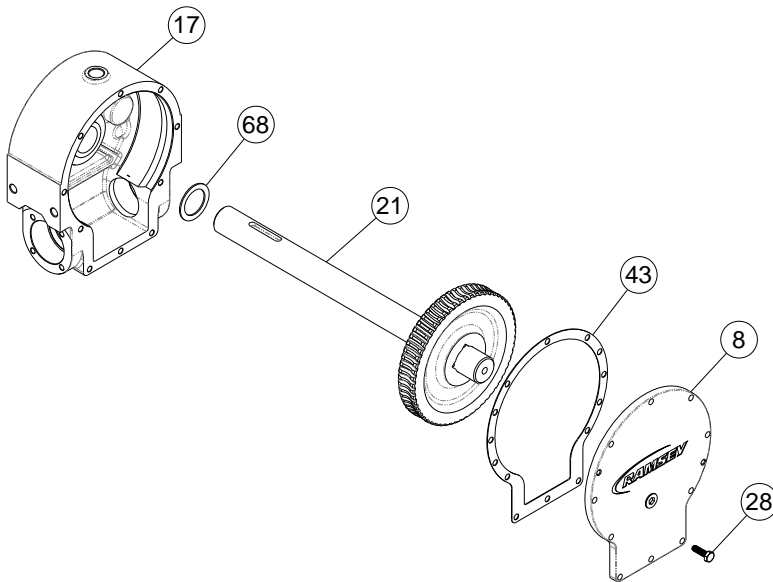

13. Apply grease to end of shaft, opposite gear. Apply grease to bushing in gear housing #17. Place greased end of shaft through thrust washer #68 and bushing in gear housing #17. Place gasket #43 onto gear housing cover #8. Apply grease to gear end of shaft and bushing in cover. Place cover onto shaft and secure to housing with five cap screws #28 at the five lower most holes.

14. Place winch, with gear housing cover down, on work bench. Drum shaft should be in vertical position. Slide thrust washer #67 over drum shaft and slide downwards until washer rests on gear housing. Set springs #64 and drag brake disc #40 into pockets of gear housing. Grease bushings in drum #9. Slide drum assembly onto drum shaft with drum jaws upward.

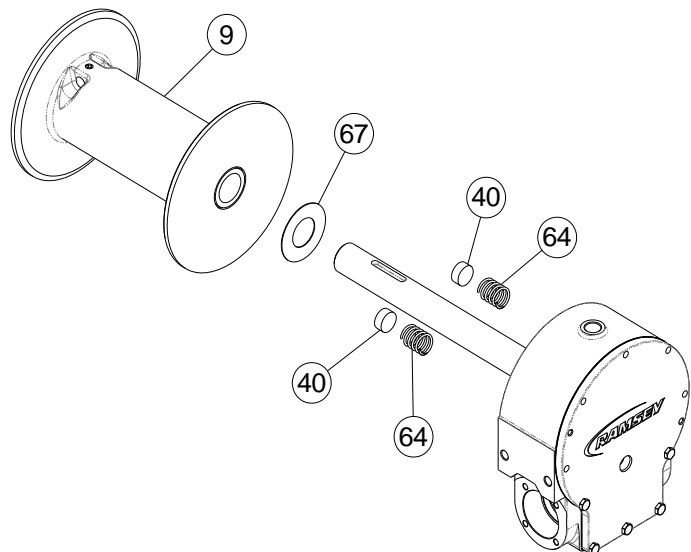

15. Place thrust washer #68 over end of drum shaft and slide downward until spacer rests on drum. Press drum downward to compress springs in gear housing.

Insert keys #45 into keyways with sharp edge of key pointing outward and notched end of keys upward. A rubber or brass mallet will be needed to gently tap keys into position.

Apply grease to keys and end of shaft. Place jaw clutch #6 over end of shaft and slide jaw clutch over keys.

Set clutch housing #16 over end of drum shaft. Pull jaw clutch housing, enough to allow yoke, in clutch housing, to fit properly in groove around jaw clutch.

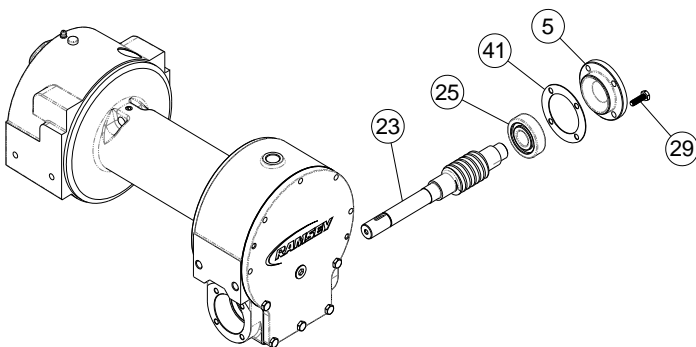
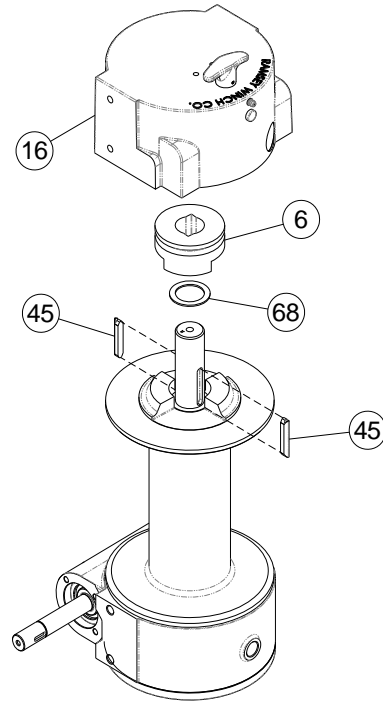

16. Press bearing #25 onto worm #23.

NOTE: Be sure thick shoulder of bearing outer race (side with manufacturer's name and part number) is out, away from worm threads. Press bearing and worm into gear housing. Slip gasket #41 onto bearing cap #5. Use four cap screws #29 to secure cap to gear housing. Torque cap screws to 7 ft-lbs (9.4 Nm) each.

17. Press bearing #25 onto worm and into worm gear housing. NOTE: Be sure thick shoulder of bearing's outer race (side with manufacturer's name and number) is out, away from worm threads. Place gasket #41 onto spur gear housing #15. Secure spur gear housing to worm gear housing using four cap screws #32. Torque cap screws to 7 ft-lbs (9.4 Nm) each.

Mount motor #49 to spur gear housing #15 using three lockwashers #39 and nuts #37. Attach solenoid cables to motor terminals. Tighten all nuts securely.

Place snap ring #63 over end of worm shaft and set into snap ring groove. Insert key #18 into keyway of worm shaft.

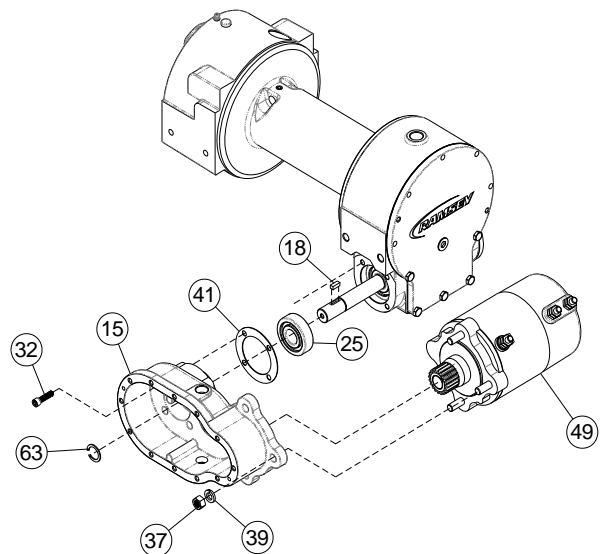

18. Place thrust washer #66 over each end of spur gear shaft #20. Set spur gear shaft assembly into bearing of spur gear housing. Slide gear #11 and thrust washer #66 over end of worm shaft.

Insert pins #55 into cover #7. Place gasket #42 onto cover. Attach cover and gasket to spur gear housing using twelve capscrews #28. Torque capscrews to 8 ft lbs (10.8 Nm.) each.

Insert plug #52 into bottom of spur gear housing. Permatex may be applied to threads to help prevent oil leakage.

Remove reducer #51 and fitting #48 from top of spur gear housing. Pour 1/2 pint of SAE 20 weight motor oil into spur gear box. Replace reducer and fitting into top of spur gear housing. Tighten reducer and fitting securely.

Attach solenoid assembly #2 to gear housing. Use two capscrews #33 and three capscrews #30 with three flatwashers #38. Tighten capscrews to 7 ft-lbs (9.4 Nm) each.

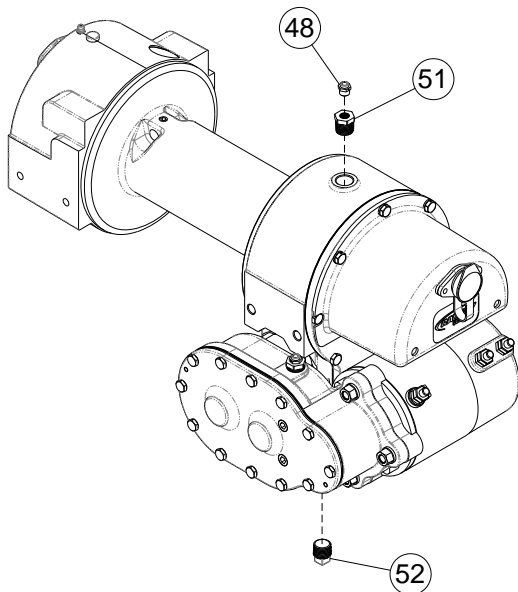
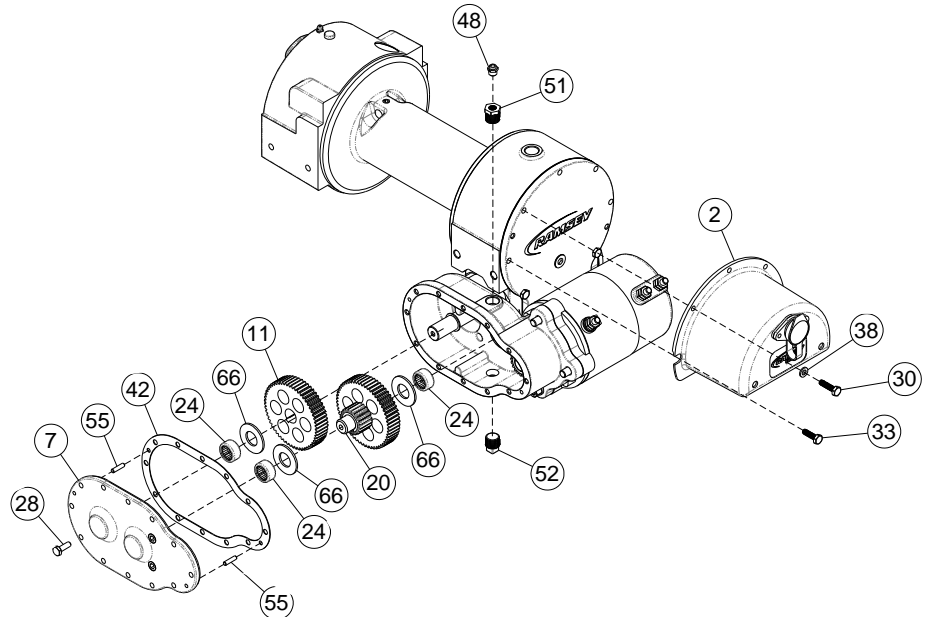

19. Insert plug #52 into bottom of gear housing. Permatex may be applied to threads to help prevent leakage.

Pour 3/4 pint of EP 140 gear oil into housing thru hole in top of housing. Insert relief fitting #48 into reducer #51. Reducer should then be placed into hole on top of gear housing. Tighten fitting and reducer securely.