

SUPERWINCH

TS35 35kN (3570kg) 24V EN14492-1 Industrial

SPECIFICATIONS

Line Pull	35 kN (3571 kg) EN
Motor	Series Wound 4.5kW 24 Volt
Gearing Ratio	3 Stage Planetary 218:1
Clutch	T handle lift & Turn
Braking	Automatic Mechanical Brake
Drum	90mm Ø x 213 mm Wide
Drum	Reinforced Steel Fabricated, Synthetic Rope Capable
	Roller Fairlead or Hawse option
Dimensions	528 mm x 180 mm x 180 mm
Mount Pattern	4 bolt (254 x 114.3mm)
Weight	Bare Winch 35.8 kg
Remote Control	Corded 3.7 M (wireless optional)
Finish	Textured Black Powder Coat
Rope	Not include
Recommended	70 kN min' breaking strain in steel or Synthetic Rope



Performance Per layer (1 kN = 101.97 kg)

Performance specifications

Rope Layer	1	2	3	Load	0 Load	Max' load
Line Pull kN	35 kN	29 kN	25 kN	Speed p/min	8.8 M	1.25
Cable Capacity (10mm)	6.2 M	13.6 M	22.3 M	Current Draw	40 A	185 A

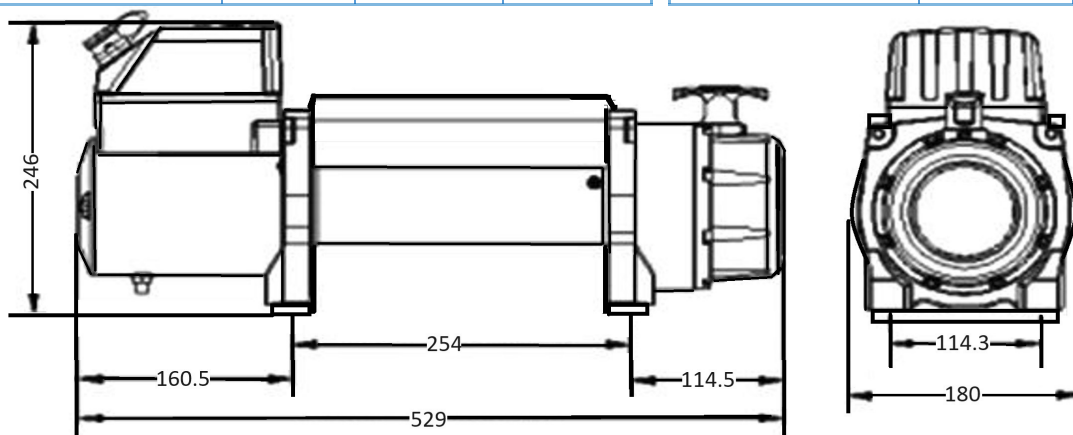

Standards & Compliances

EN 14492-1 / CE Directives—Machinery 2006/42/ EC: Noise Emission 2000/14/EC

Electromagnetic Compatibility : 2014/30/EC

